

COVID-19 Vaccine Implementation

Nancy Messonnier, MD

December 8, 2020

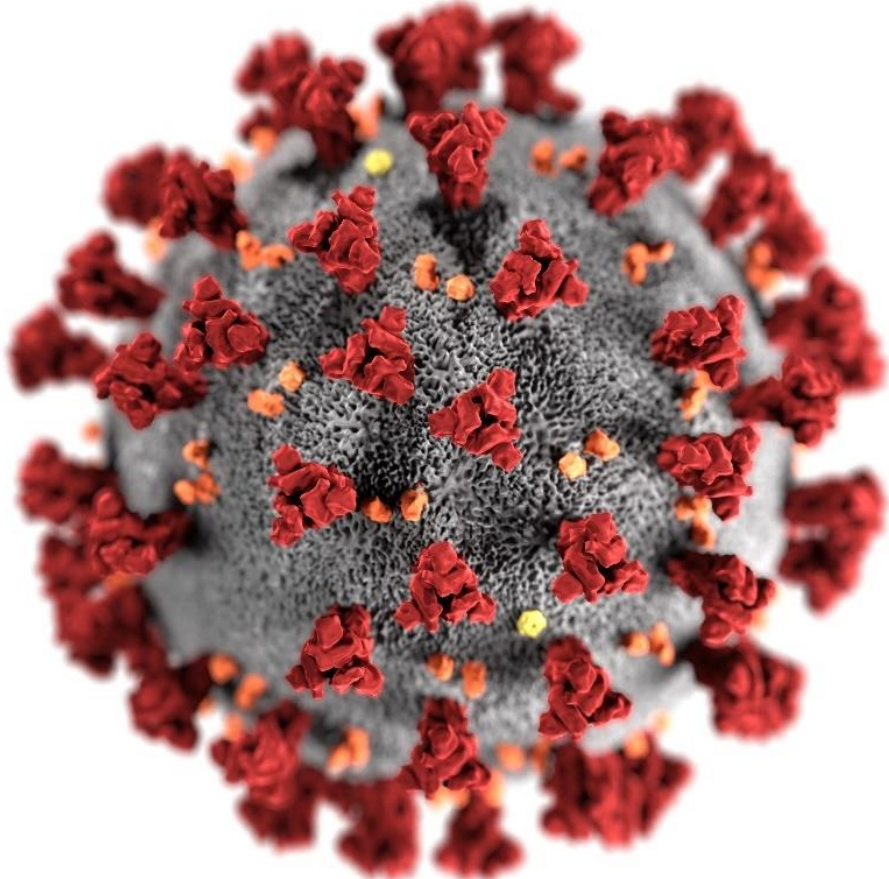

Distribution will adjust as volume of vaccine doses increases

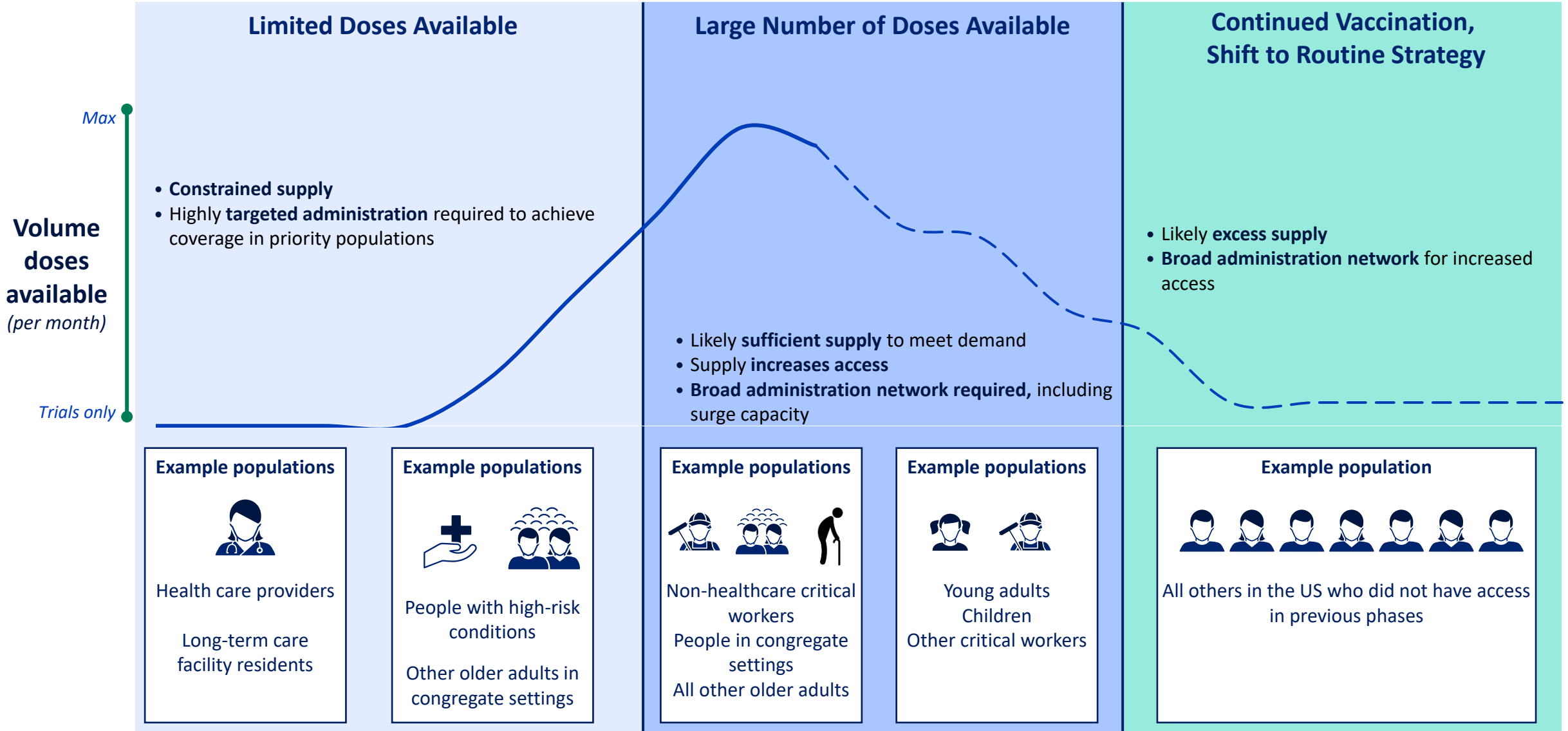

Distribution Concept of Operations

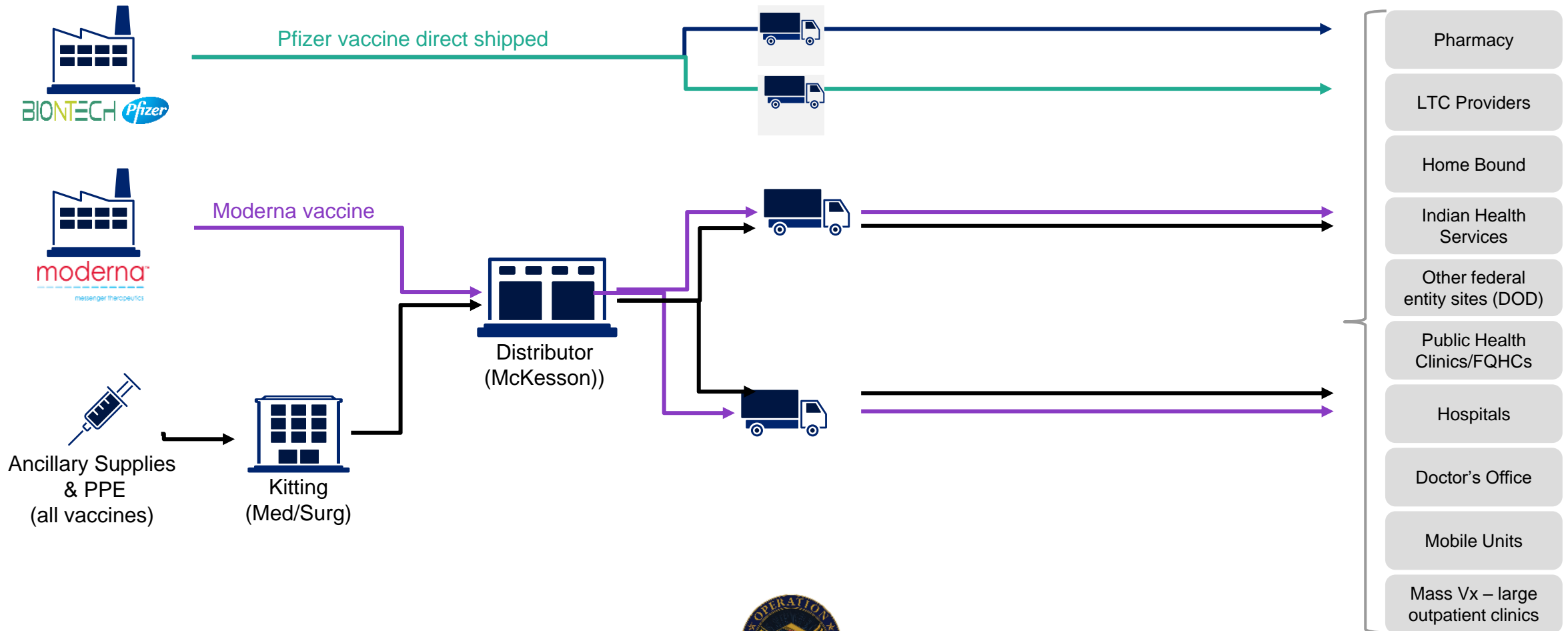

OWS coordination cell

Example of a possible Phase 1 sequence

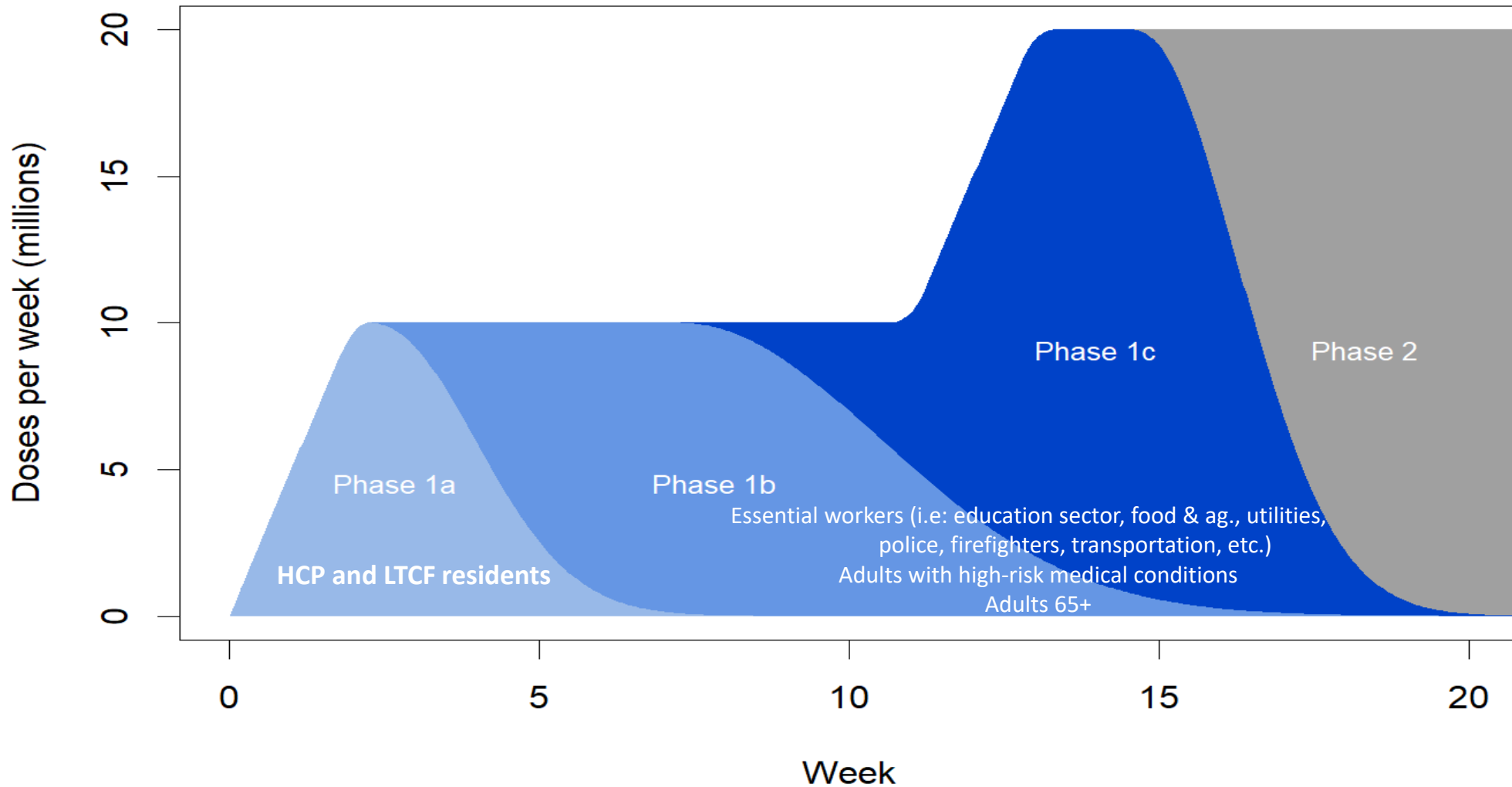

COVID-19 Vaccination Provider Recruitment and Enrollment

- Ongoing, variable numbers by state
- States working with healthcare and hospital systems and local health departments
 - Closed pods and open pods
- Training of COVID-19 vaccination providers is vital to ensure the success of the COVID-19 Vaccination Program
- Training and clinical materials include:
 - Toolkits for health systems and clinics, long-term care facilities, and health departments
 - Training materials on vaccine administration, storage and handling, vaccine products, etc.

Available Soon! – Vaccine Communication Toolkits

- **Ready-made materials to inform healthcare providers, patients, and communities about COVID-19 vaccines**
 - Discussion guide and readiness checklist
 - Slide decks for immunization coordinators, healthcare teams, and other support personnel
 - Colorful posters
 - Informational factsheets and FAQs
 - Sample social media messages and graphics
 - Drop-in articles and blog posts
 - “Vaccinated against COVID” button design to make vaccination visible



COVID-19 Vaccine Safety Strategy

- 1. Use established systems** to implement heightened safety monitoring for COVID-19 vaccines
- 2. Develop new platforms** and leverage other federal data sources to complement existing systems
- 3. Communicate clearly** on the vaccine safety process and systems now; provide COVID-19 vaccine safety data and monitoring results once available



The Problem: Decline in COVID-19 Vaccine Acceptability

- **58%** of the general public said they would receive a COVID-19 vaccine (as of an October 2020 Harris Poll)

Factors weighing on acceptance:



Concern about side effects



Efficacy



Risk perception



Associated costs

COVID-19 vaccine more acceptable if:



Healthcare provider said it was safe



There are no costs to the individual



It would help get back to school and work



They could get it easily



Vaccinate with **Confidence**

A National Strategy to Reinforce Confidence in COVID-19 Vaccines

Reinforce Trust

Objective: Regularly share clear and accurate COVID-19 vaccine information and take visible actions to build trust in the vaccine, the vaccinator, and the system.

Empower Healthcare Providers

Objective: Promote confidence among healthcare personnel in their decision to get vaccinated and to recommend vaccination to their patients.

Engage Communities & Individuals

Objective: Engage communities in a sustainable, equitable and inclusive way—using two-way communication to listen, increase collaboration and build trust in COVID-19 vaccine.

COVID-19 Vaccine Implementation

- There will be **unanticipated challenges**, but CDC will continue to work closely with partners to **find solutions and overcome obstacles**.
- Vaccines are an important tool to control the pandemic, but we need to continue to **wear masks, social distance, and wash hands**.
- **Jurisdictions are under immense stress** and will be implementing COVID-19 vaccination amidst a surge in disease, strain on the healthcare system, and nearly a year spent fighting this pandemic.
- We need to continue to lay the foundation to **build vaccine confidence** across the United States.

What can you do now?

- Stay up to date on the latest news
- Follow CDC, FDA, health departments on social media
- Be in contact with health department counterparts
- Be aware of jurisdictions' planning activities
- Be a trusted source professionally and personally

Thank you



The findings and conclusions in this report are those of the authors and do not necessarily represent the official position of the Centers for Disease Control and Prevention.

For more information, contact CDC
1-800-CDC-INFO (232-4636)
TTY: 1-888-232-6348 www.cdc.gov